



INSTALLATION AND MAINTENANCE INSTRUCTIONS THERMOSTATS ADCATROL T.205 AND T.405

GENERAL

- These instructions must be carefully read before any work involving products supplied by VALSTEAM ADCA ENGINEERING S.A. is undertaken.
- The installation procedure is a critical stage in a life of a valve and thermostat, care should be taken to avoid damage to the valve, thermostat or equipment.
- Control valves are designed to give accurate control. They give their maximum performance only when the equipment and piping associated with them is correctly sized and installed in accordance with our recommendations.
- Referring to the name-plate located on valve and thermostat, check that the product is suitable for the intended use/application as follows:
 - the body material must be compatible with the process fluid
 - compatibility with the pressure and temperature and their maximum and minimum values
- Adcatrol control valves are not intended to withstand external stresses that may be induced by any system to which they are fitted. It is the responsibility of the installer to consider these stresses and take adequate precautions to minimise them.

Warning!

- At start up, the presence of small particles in the fluid (dirt, scale, weld splatters, etc) may cause an unperfected closure of the seat. If this occurs, proceed to an accurate cleaning.
- Do not touch the equipment without appropriate protection during working operation because it may conduct heat if the used fluid is at high temperature.
- Before starting maintenance be sure that the equipment is not pressurized or hot. Even if upstream and downstream isolating valves have been closed care should be taken since fluid under pressure may be trapped between them.
- The equipments must be used within the working temperature and pressure limits laid down for them, otherwise they may fail (refer to nameplate and/or IS- Information Sheet).
- All work must be carried out or be supervised by a suitably competent person.
- Manual handling of products may present a risk of injury. You are advised to assess the risks taking into account the task, the individual, the load and the working environment.
- Before starting work ensure that you have suitable tools and/or consumables available. Use only genuine ADCA replacement parts.
- Do not remove the nameplate attached to the equipment. Serial number and other useful information is stamped on it.

INSTALLATION



ATTENTION

- Before to install remove plastic covers placed on flanges or connection ends. The equipment has an arrow or Inlet/Outlet designations. Be sure that it will be installed on the appropriate direction.
- Take care with jointing material to ensure that none may be permitted to block or enter the valve.
- Control valves are recommended to be fitted with the centre line of the valve in a vertical position to ensure that the best results are obtained. Depending on the temperature of the medium flowing through the valve, the valve can be fitted with the thermostat above or below in accordance with the following:

- up to 150°C: optional, up or down

- from 150 to 350 °C: always down (and, in addition, fit cooling unit K1 between valve and thermostat)

- An ADCA pipeline strainer should be installed upstream of the valve to protect from dirt which could damage the valve or cause mal-functioning.

- The control valve pipe work should be properly supported and free from strain and it should not be subjected to undue surges of pressure.

For steam installations we strongly recommend that the control valve is positioned where condensation is unable to collect or that, alternatively, separators and steam traps are fitted so that the pipe work drains correctly. The start up condition should be considered.

- If the system cannot be stopped for maintenance it is recommended that isolating valves are installed upstream and downstream of the control valve together with a by-pass manual regulating valve. The process can be then controlled manually during the control valve maintenance.

- A safety device should be included in the system to prevent dangerous overpressure or over temperature occurrence, if applicable.

- Self operated control valves can be supplied with different kind of thermostats. All these components have different limiting conditions which are specified on the nameplates and catalogues and they must be respected.

- Lock nut (33 from Fig.1) must be slackened. Use packing tape on the thread of the sensor connection (32), screw into place and tighten to form a seal against the cone (30).

- Mount the thermostat on the valve ensuring that the gasket (2) provided is in place, and tighten the union.

- On installations likely to vibrate (e.g. marine equipment), support the control cylinder. The end of the capillary tube nearest the handle (28) must be free to move, as the handle – and thus the tube – moves longitudinally when it is turned.

- It is not normally necessary to install a sensor pocket PK as most repairs can be carried out with the sensor in place. They are used whenever it is impossible to empty the system or the tank.

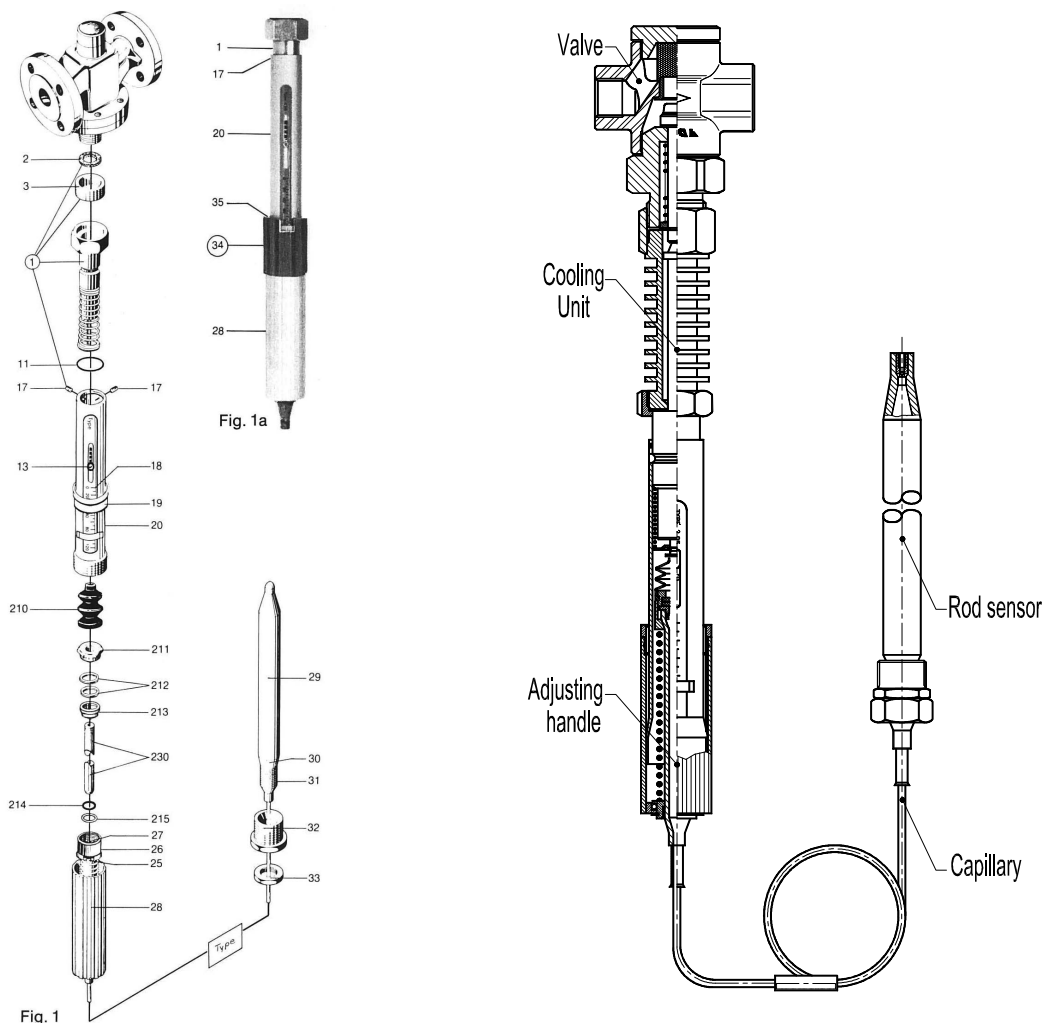

MAINTENANCE

- Setting the temperature: turn the handle (28) until the upper edge of the indicating sleeve (19) indicates the desired temperature on the scale (18).
- Calibration: if the pre-set temperature fails to agree with the actual temperature achieved, the thermostat must be calibrated. Allow the control thermometer to settle, then – without turning the handle (28) – loosen the screw (13) and push the scale (18) until it shows the same temperature as that actually obtained.
- If the fluid system is defective, the handle (28) can be used as a temporary means to control the regulating valve.
- If the medium leaks from the valve, it is recommended that the stuffing box (1) should be renewed. Close the stop valves if any, and unscrew the handle (28) until there is no doubt that the valve is not open (or closed, in case of reverse action valve). Loosen screws (17) and remove supporting tube (20). The stuffing box is now accessible.
- Repair of valves: dismantle the thermostat and the valve. Remove dirt or other foreign materials. If necessary, regrind valve seat and cone.
- For further information refer to the relevant IS brochure or consult the factory or distributor.



STEAM EQUIPMENT

TYPICAL INSTALLATION

Please consult the available standard assembling drawings or consult the factory for a specific installation drawing.



ATTENTION

- **LOSS OF WARRANTY:** Total or partial disregard of above instructions involves loss of any right to warranty.