

Inverted Bucket Steam Traps - IB 12

Description

IB 12 series inverted bucket steam traps are recommended for all services where the most important requirements are overall operating efficiency and long, trouble-free service life. They operate intermittently, either wide open or tightly closed and are therefore best suited for service at medium and high steam pressures.

Connections are female screwed horizontal.

Article no.	Type	Size	Price
BSP			
445690	IB12-4	1/2"	£213.90
445621	IB12-8	1/2"	£213.90
445689	IB12-12	1/2"	£213.90
440926	IB12-4	3/4"	£213.90
348410	IB12-8	3/4"	£213.90
440927	IB12-12	3/4"	£213.90
FLANGED		ON REQUEST	

Materials

1	Body	GGG40
2	Cover	GGG40
3 *	Gasket	Non Asbestos
4 *	Seat	AISI 410
5 *	Valve	AISI 410
6 *	Lever	AISI 304
7 *	Bucket	AISI 304
8 *	Strainer Screen	AISI 304
9	Gasket	316/graphite
10	Plug	C22.8
11	Bolts	Steel 8.8
* Available Spare Parts		

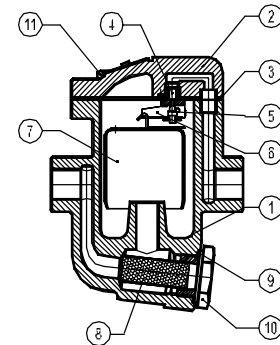

Flow Rate Capacity in Kg/h

MODEL SIZE	DIFFERENTIAL PRESSURE (bar)									
	1	2	3	4	5	6	7	8	10	12
IB12-4 1/2"-3/4"	280	390	470	530						
IB12-8 1/2"-3/4"	190	260	320	360	400	430	460	500		
IB12-12 1/2"-3/4"	160	220	260	290	320	360	370	400	440	490

Inverted Bucket Steam Traps - IBB 12

Description

IBB 12 series inverted bucket steam traps are recommended for all services where the most important requirements are overall operating efficiency and long, trouble-free service life. They operate intermittently, either wide open or tightly closed and are therefore best suited for service at medium and high steam pressures.

Connections are female screwed horizontal.

Article no.	Type	Size	Price
BSP			
348411	IBB12-4	3/4"	£360.20
348412	IBB12-8	3/4"	£360.20
444468	IBB12-12	3/4"	£360.20
441343	IBB12-4	1"	£360.20
348415	IBB12-8	1"	£360.20
443802	IBB12-12	1"	£360.20
FLANGED		ON REQUEST	

Materials

1	Body	GJS-400-15 / 0.7040
2	Cover	GJS-400-15 / 0.7040
3 *	Gasket	Stainless St. / Graphite
4 *	Seat	AISI 410 / 1.4006
5 *	Valve	AISI 410 / 1.4006
6 *	Lever	AISI 304 / 1.4301
7 *	Bucket	AISI 304 / 1.4301
8 *	Strainer screen	AISI 304 / 1.4301
9	Gasket	Stainless St. / Graphite
10	Plug	A105 / 1.0432
11	Bolts	Steel 8.8
* Available Spare Parts		

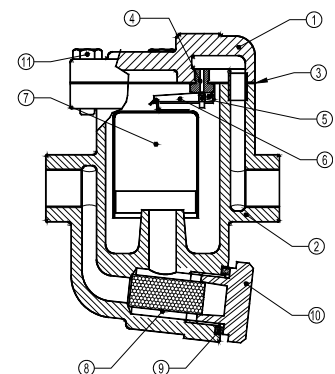

Flow Rate Capacity in Kg/h

Model Size	DIFFERENTIAL PRESSURE (bar)										
	1	2	3	4	5	6	7	8	10	11	12
IBB12-4 3/4"-1"	1090	1380	1550	1670							
IBB12-8 3/4"-1"	725	910	1030	1100	1160	1210	1250	1290			
IBB12-4 3/4"-1"	570	720	810	880	920	950	985	1010	1060	1060	1100