

WINDOW SIGHT GLASS DW40SS

DESCRIPTION

For monitoring the right operation of a steam trap, in order to avoid leakages of live steam and, consequently, great energy losses, a sight glass is recommended to be installed downstream of the steam trap. The double window DW40 sight glasses have been designed for this particular application.

- OPTIONS:** Mica shield discs for use with steam.
- USE:** Condensate pipes, downstream of the steam traps.
- AVAILABLE MODELS:** DW40SS – stainless steel.
- SIZES:** 1/2" to 2"; DN 15 to DN 50.
- CONNECTIONS:** Female threaded ISO 7 Rp or NPT.
Flanged EN 1092-1 PN 40.
Flanged ASME B16.5 Class 150 or 300.
- INSTALLATION:** Horizontal or vertical installation.
See IMI – Installation and maintenance instructions.

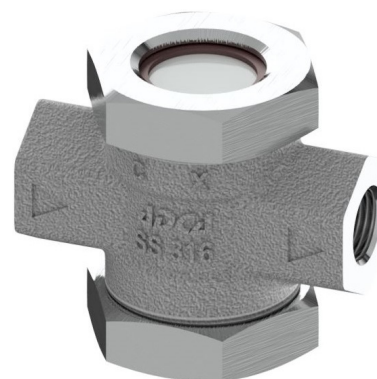

1/2" to 1"



1 1/4" to 2"



DN 15 to DN 25

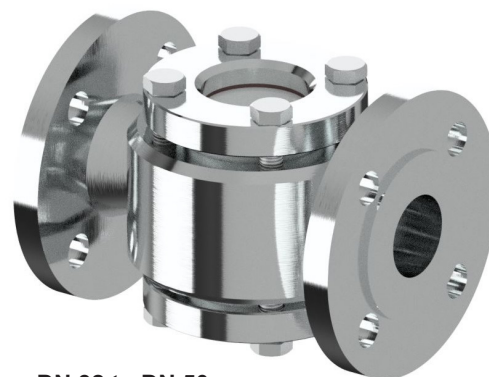

DN 32 to DN 50

BODY LIMITING CONDITIONS

FLANGED CLASS 150 **	FLANGED PN 25 *	FLANGED CLASS 300 **	FLANGED PN 40 *	RELATED TEMPERATURE
ALLOWABLE PRESSURE	ALLOWABLE PRESSURE	ALLOWABLE PRESSURE	ALLOWABLE PRESSURE	
15,3 bar	25 bar	39,9 bar	40 bar	-10 / 50 °C
13,3 bar	23,6 bar	34,4 bar	37,9 bar	100 °C
12 bar	21,5 bar	31,3 bar	34,4 bar	150 °C
11,1 bar	19,8 bar	28,8 bar	31,8 bar	200 °C
10,2 bar	18,6 bar	26,6 bar	29,9 bar	250 °C

* According to EN 1092-1:2018; ** According to EN 1759-1:2004.
Remarks: For applications with steam, use mica shield discs;
Rating PN 40 for sizes up to DN 25; Rating PN 25 for sizes from DN 32 to DN 50.
Rating PN 40 or lower for threaded versions.

CE MARKING – GROUP 2 (PED – European Directive)

PN 40 / CLASS 300	PN 25	CLASS 150	Category
1/2" to 1" – DN 15 to 25	1 1/4" to 1 1/2" – DN 32 to 40	1/2" to 2"	SEP
–	2" – DN 50	–	1 (CE Marked)

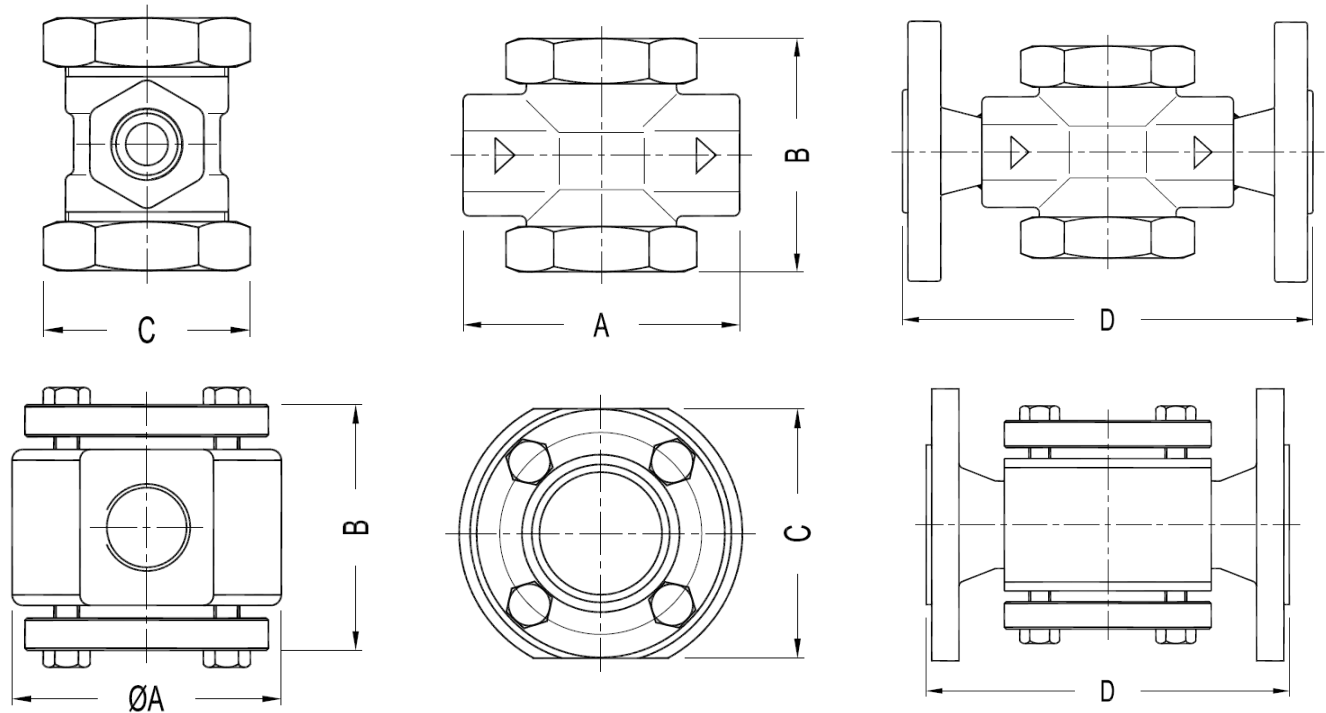

DIMENSIONS (mm)

SIZE	THREADED			WEIGHT (kg)	PN 40		CLASS 150		CLASS 300	
	A	B	C		D	WEIGHT (kg)	D	WEIGHT (kg)	D	WEIGHT (kg)
1/2" - DN 15	90	80	60	1	150	2,8	150	2,2	150	2,6
3/4" - DN 20	90	80	60	1	150	3,2	150	2,6	150	3,5
1" - DN 25	100	87	65	1,2	160	3,7	160	3,3	160	4,1
1 1/4" - DN 32	130	115	114	7,4	180	11	180	10,2	180	11,3
1 1/2" - DN 40	130	115	114	7,2	200	11,5	200	11	200	12,7
2" - DN 50	130	125	114	7,7	230	13,5	230	13	230	14,3

MATERIALS

POS. N°	DESIGNATION	1/2" to 1" DN 15 to 25	1 1/4" to 2" DN 32 to 50
1	Body	AISI 316L / 1.4404	AISI 316L / 1.4404
2	Glass nut / flange	AISI 316L / 1.4404	AISI 316L / 1.4404
3	* Gasket	Stainless steel / Graphite	Stainless steel / Graphite
4	* Window glass	Tempered borosilicate glass	Tempered borosilicate glass
5	Bolts	-	Stainless steel A2-70

* Available spare parts.

